



Controllo Easy Touch

- Pratica e intuitiva tastiera Touch
- Facile settaggio del tempo di vuoto e di saldatura
- Visualizzazione percentuale vuoto e tempo residuo
- 10 programmi memorizzabili a piacere
- Programmi speciali:
 - Marinatura
 - Preriscaldamento pompa e ciclo pulizia olio
 - Vuoto esterno a tempo (escluso Vertigo 30)
- Memorizzazione ultima impostazione
- Contacigli utilizzo totale
- Messaggio cambio olio

Easy Touch Control

- *Practical and intuitive touch keyboard*
- *Easy setting of the vacuum and sealing time*
- *Display shows vacuum percentage and time*
- *10 programs that can be stored as desired*
- *Special programs:*
 - *Marinade*
 - *Pump preheating and oil cleaning cycle*
 - *Timed external vacuum (not for Vertigo 30)*
- *Last setting memorization*
- *Total use cycle and time counter*
- *Oil change message*



Controllo M

- Pulsante Start/Stop per vuoto esterno
- Led di stato
- Pulsante annullamento saldatura/ciclo di lavorazione
- Pratiche e semplici manopole per regolare tempo di vuoto e saldatura

M Control

- *Start/Stop button for external vacuum*
- *Status LED*
- *Seal/working cycle cancel button*
- *Practical and simple knobs for adjusting vacuum and sealing time*



Controllo TOP

Controllo touch intelligente, retroilluminato, completo ma intuitivo, con collegamento WiFi

- Sistema di controllo elettronico con sensore di pressione per il vuoto automatico
 - Impostazione vuoto a Mbar, a Percentuale o a Tempo a preferenza dell'utilizzatore
 - Sensore di controllo di temperatura e protezione della pompa
 - Percentuale vuoto automatico regolabile 50-100% o a vuoto residuo in Mbar
 - Programma dedicato per liquidi
 - Programmi dedicati per marinatura
 - 10 programmi Multistep memorizzabili a piacere
 - 6 Lingue disponibili
 - Impostazione tempo saldatura, vuoto e gas con scala 1/10 sec.
 - Visualizzazione percentuale vuoto e tempo residuo
 - Previsione delle operazioni di manutenzione per garantire una maggior durata nel tempo
 - Segnale di avviso sostituzione olio e filtro
 - Ciclo di preriscaldamento e pulizia olio
 - Contacigli totali
 - Contatore utilizzo pompa
 - Softair elettronico con 3 livelli di regolazione
- Con questo controllo si possono integrare i seguenti optional*:
- Impianto gas inerte (MAP)
 - Stampante termica
 - A.O.R.
 - SanO3
 - SAT SYSTEM

* contatta il ns. ufficio per conoscere quali opzioni possono essere disponibili contemporaneamente sullo stesso apparecchio

TOP Control

Smart, backlit, comprehensive yet intuitive touch control with WiFi connection

- *Electronic control system with pressure sensor for automatic vacuum*
 - *Vacuum setting at Mbar, Percentage or Time according to the user*
 - *Temperature control sensor and pump protection*
 - *Adjustable automatic vacuum percentage 50-100% or with residual vacuum in Mbar*
 - *Dedicated program for liquids*
 - *Dedicated programs for marinating*
 - *10 Multistep programs that can be stored as desired*
 - *6 Languages available*
 - *Setting sealing time, vacuum and gas with 1/10 sec scale*
 - *Displays vacuum percentage and remaining time*
 - *Predictive maintenance operations to ensure a longer duration over time*
 - *Oil and filter warning signal*
 - *Oil preheating and cleaning cycle*
 - *Total cycle counter*
 - *Pump usage hour counter*
 - *Electronic Softair with 3 adjustment levels*
- This control can integrate the following options*:*
- *Inert gas system*
 - *Thermal printer*
 - *A.O.R.*
 - *SanO3*
 - *SAT SYSTEM*

* contact our office to find out which options may be available at the same time on the same device



W8 Top



W8 Easy Touch



YouTube



Industria 4.0

W8 TOP / W8 EASY TOUCH

sottovuoto

vacuum packaging machines

- Straordinario design riduce l'ingombro della macchina e migliora la praticità
- Campana di grande volume in plexiglass termoformato di grosso spessore sui mod. 50 e 70, ad iniezione in Tritan sui mod. 30 e 40
- Barra saldante facilmente rimovibile
- Estrema facilità di pulizia grazie alla perfetta planarità del piano di appoggio prodotto realizzato in in acciaio inox AISI 304 spessore 5 mm
- Sollevamento coperchio automatico a mezzo di pistoncini pneumatici
- Supporto per buste con liquidi

Opzionali:

- Tubo per aspirazione esterna
- Vasche GN per aspirazione esterna
- Ripiano in plexiglass trasparente

W8 Easy Touch

- Controllo EASY TOUCH
- Non disponibile con stampante, gas, AOR, SanO₃, Sat System

W8 TOP

- Controllo TOP
- Compatibile Industria 4.0

Opzionali:

- Impianto per gas inerte (MAP).
- Stampante termica automatica per data, ora dati confezionamento
- AOR cambio olio automatico
- SanO₃ sistema integrato e automatico di sanificazione

- *Extraordinary design reduces the footprint of the machine and improves comfort*
- *Bell in great development of volume plexiglass thermoformed thick on mod. 50 and 70, injection in Tritan on mod. 30 and 40*
- *Easily removable sealing bar*
- *Extremely easy to clean thanks to the flatness of the chamber made on AISI 304 stainless steel 5 mm thick*
- *Automatic lifting the lid by means of pneumatic pistons*
- *Support for vacuum bags with liquids*

Opzionali:

- *Hose for external suction*
- *GN tanks for external suction*
- *Plexiglass support*

W8 Easy Touch

- *EASY TOUCH controls*
- *Not available with printer, gas flush, AOR, SanO₃, Sat System*

W8 TOP

- *TOP controls*

Opzionali:

- *Inert gas system (MAP)*
- *Automatic thermal printer by date, time and packing specifications*
- *AOR - Automatic Oil Replacement*
- *SanO₃ - integrated and automated sanitizing system*



W8 TOP 40 BX
con gas inerte e AOR opzionali
with inert gas and AOR optional



W8 TOP 70 TB



Barra saldante
Single sealing bar



Doppia barra saldante W8 50 DB
Double sealing bar W8 50 DB



Tripla barra saldante W8 70 TB
Triple sealing bar W8 70 TB



Sospensione coperchio ammortizzato
Lid damper suspension system



Possibilità di saldare più buste sovrapposte
More overlapped bags can be sealed at once to speed intense work load



Supporto per buste con liquidi
Support for vacuum bags with liquids



Utilizzo di buste goffrate per il vuoto fuori campana
Embossed bags can be used to seal bigger products holding them outside the lid



Estrema facilità di pulizia
Easy to clean



Facile manutenibilità
Easy maintainability



W8 30 EASY TOUCH DX



W8 40 EASY TOUCH BX



W8 TOP 50 DX

Optionals



Gas inerte e AOR (escluse le Easy)
Inert gas and AOR (the Easy excluded)



Barra saldante con taglio
Sealing bar with cut-off wire



Stampante integrata
Built-in printer



Carta adesiva per stampante integrata
Adhesive paper for built-in printer

SANO₃
AUTOMATIC OZONE SANITIZATION

SanO₃ è un sistema integrato e automatico di sanificazione della camera e dei vari condotti che, tramite un generatore di ozono, riesce ad arrivare dove i tradizionali sistemi di sanificazione non arrivano.

Solo per i mod. W8 TOP 40, 50 e 70

SanO₃ is an integrated and automated sanitizing system that works with an ozone generating cell to deeply sanitize the chamber and all the air pipes reaching the best result where other sanitizing procedures cannot get. Only on mod. W8 TOP 40, 50 and 70



PATENTED



W8 50 DB
Ripiano in plexiglass
Plexiglass shelf



Cavalletto alluminio per W8 50 - con e senza ruote
o con piano inferiore per serbatoi AOR
mm 586x564 h.757 + h.110 mm con ruote

*Aluminium table base to W8 50 - with or without wheels
or with lower shelf for AOR tanks
mm 586x564 h.757 + h.110 mm with wheels*

Optionals



Tubo per aspirazione esterna
External suction hose

Contenitori GN 1/1 - 1/2 (h.100/150)
con coperchio inox
*Containers GN 1/1 - 1/2 (h.100/150)
with s/steel cover*

0-100% vuoto / vacuum

Contenitori GN 1/1 - 1/2 - 1/3 (h.100/150)
con coperchio in Tritan
*Containers GN 1/1 - 1/2 - 1/3 (h.100/150)
with cover in Tritan*

0-80% vuoto / vacuum



AOR[®]
AUTOMATIC OIL REPLACEMENT

PATENTED

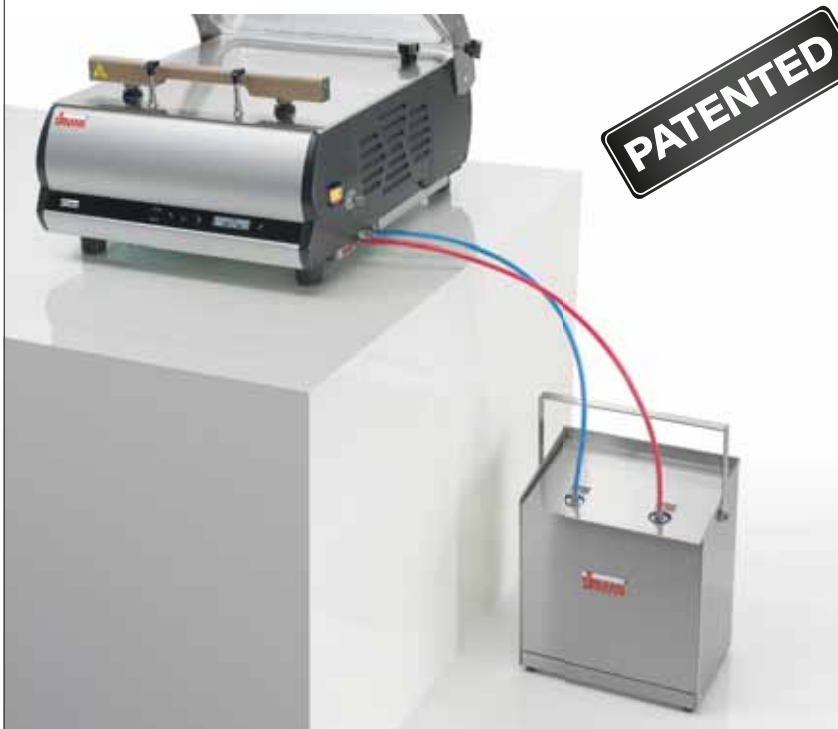

Un brevetto esclusivo di Sirman, sempre al primo posto per tecnologia sottovuoto e sous vide.

Gestisce il cambio olio in automatico tramite dei serbatoi esterni che permettono un'autonomia da 1 a 3 anni senza bisogno di interventi sulla pompa.

La macchina provvede automaticamente quando serve sostituire l'olio, preservando la pompa e prolungandone la garanzia fino a 3 anni (per macchine connesse in Wi-Fi).
Dimensioni mm 230x330 h.341

Automatic Oil Replacement, an exclusive patent by Sirman, always in pole position for vacuum and sous vide technology.

*The machine automatically manages the oil changing, preserving the pump from damage and thus extending the warranty of the pump to 3 years (for machines connected via Wi-Fi).
Dimensions mm 230x330 h.341*

SAT SYSTEM

sottovuoto con connessione satellite *vacuum packaging machines with satellite*

Sat System è una funzionalità accessoria della scheda TOP che permette di collegare velocemente alla macchina principale (solo W8 40 o 50 Top) a una seconda macchina satellite per essere utilizzata al posto o in contemporanea alla macchina principale. Con un investimento ridotto si può così raddoppiare la produttività come se si avessero a disposizione due macchine oppure si può avere un'appendice dedicata in modo specifico ai prodotti liquidi o polverosi (Vertigo SAT 30).

Ideale per:

- tutte le situazioni igienico sanitarie dove è richiesto l'uso di macchine diverse per prodotti diversi.
- chi vuole essere più veloce nella preparazione del proprio carico di lavoro sottovuoto
- chi vuole sfruttare la massima capacità delle buste con i prodotti liquidi (utilizzando Vertigo SAT 30)

Si consiglia di utilizzare unità satelliti di pari grandezza della macchina principale o più piccole



W8 TOP 40 or 50

VERTIGO SAT 30



Sat System is an optional function of the TOP control board that allows you to quickly connect a second satellite machine to the main machine (only W8 40 or 50 Top) to be used instead of or simultaneously with the main machine.

With a small investment, you can thus double productivity as if you had two machines available or you can have a satellite machine specifically dedicated to liquid or powdery products (Vertigo SAT 30).

Ideal for:

- all health and hygiene situations where the use of different machines for different products is required.
- those who want to be faster in preparing their vacuum workload
- those who want to exploit the maximum capacity of the bags with liquid products (using Vertigo SAT 30)

It is recommended to use satellite units of the same size as the main machine or smaller

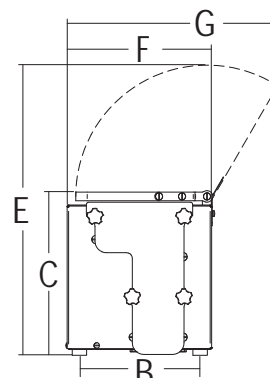
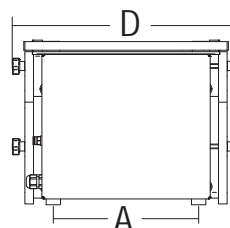
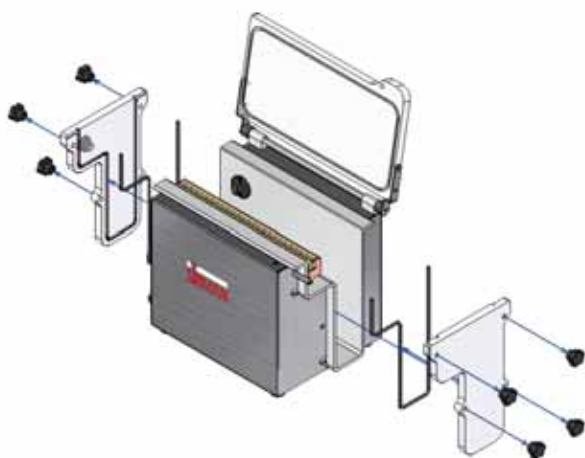

		A	B	C	D	E	F	G			
	mm	mm	mm	mm	mm	mm	mm	mm	kg	mm	kg
Vertigo SAT 30	310	253	210	284	396	505	252	366	13	-	-



W8 TOP 40 or 50



W8 SAT 30, 40 or 50 / 50 DB



Predisposizione Sat System
Sat System ready

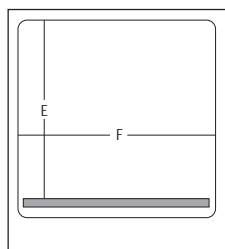

W8 30-40-50

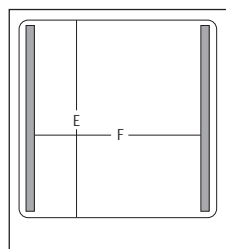

W8 50 DB

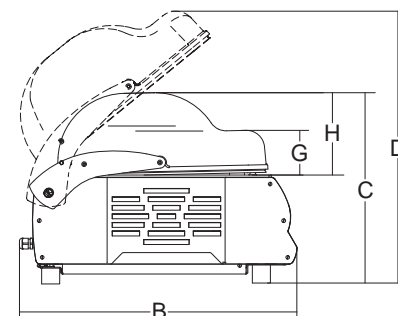
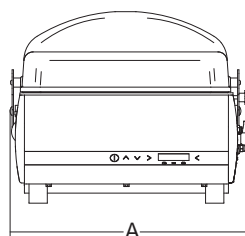

	mm	mm	mm	mm	mm	mm	mm	mm	mm	kg	mm	kg
W8 SAT 30	310	402	525	408	587	334	340	95	170	24	720x570x770	34
W8 SAT 40	410	493	585	422	630	390	430	99	180	31	760x640x770	41
W8 SAT 50	510	609	640	420	605	430	540	90	210	43	840x870x750	53
W8 SAT 50 DB	410x2	609	640	420	605	424	428	90	210	45	840x870x750	55

Optionals



Buste per sottovuoto / Vacuum bags

Lisce μm 70 Smooth μm 70	Lisce μm 90 Smooth μm 90	Goffrate μm 105 Embossed μm 105	Cook&Chill μm 80 Cook&Chill μm 80	Compostabili Compostable
(-40°C / +40°C)	(-40°C / +40°C)	(-40°C / +40°C)	(-40°C / +120°C)	(-20°C / +120°C)
cm 20x30	cm 17x25	cm 16x23	cm 15x20	cm 15x20
cm 25x35	cm 20x30	cm 20x30	cm 20x30	cm 20x30
cm 30x40	cm 25x35	cm 25x35	cm 25x35	cm 25x35
cm 40x50	cm 30x40	cm 30x40	cm 30x40	cm 30x40
	cm 35x45	cm 35x45		
	cm 40x50	cm 40x50		

IDENTIFICAZIONE MODELLI
 D = Pompa DVP
 B = Pompa Busch
 X = piano appoggio inox
 12 = pompa aspirazione 12 mc
 DB = doppia barra saldante
 TB = tripla barra saldante
 P = da pavimento

ORDERING SYSTEM
 D = DVP
 B = Pump Busch
 X = flat s/steel countertop
 12 = suction pump 12 mc
 DB = double sealing bar
 TB = Triple sealing bar
 P = floor standing

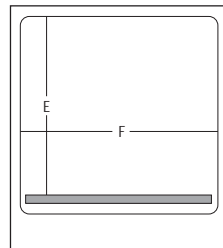

W8 30-40-50

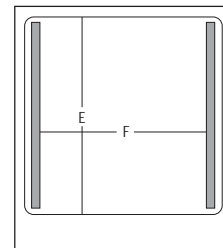

W8 50 DB

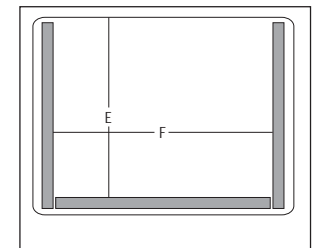

W8 70 TB

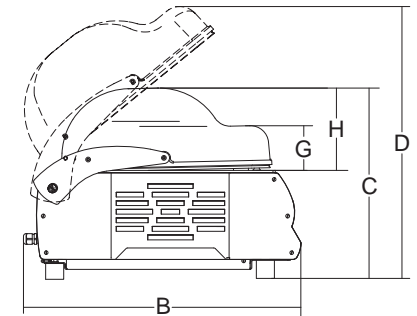
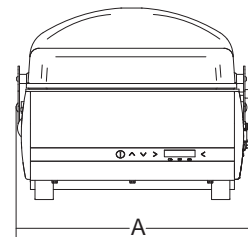

	kw	mc/h	mm	mm	mm	mm	mm	mm	mm	mm	mm	mm	mm	kg	mm	kg
W8 30 Easy Touch DX	0.35	1ph	8	310	340x360 h.160	402	525	408	587	334	340	95	170	38	720x570x770	48
W8 30 Easy Touch BX	0.35	1ph	8	310	340x360 h.160	402	525	408	587	334	340	95	170	38	720x570x770	48
W8 30 Easy Touch DX 12	0.45	1ph	12	310	340x360 h.160	402	525	408	587	334	340	95	170	38	720x570x770	48
W8 40 Easy Touch DX 12	0.45	1ph	12	410	430x410 h.170	493	585	422	630	390	430	99	180	54	760x640x770	64
W8 40 Easy Touch DX	0.75	1ph	20	410	430x410 h.170	493	585	422	630	390	430	99	180	56	760x640x770	66
W8 40 Easy Touch BX	0.75	1ph	20	410	430x410 h.170	493	585	422	630	390	430	99	180	56	760x640x770	66
W8 50 Easy Touch DX	0.75	1ph	20	510	545x460 h.190	609	640	420	605	430	540	90	210	70	840x870x750	86
W8 50 Easy Touch BX	0.75	1ph	20	510	545x460 h.190	609	640	420	605	430	540	90	210	70	840x870x750	86
W8 Top 30 DX	0.35	1ph	8	310	340x360 h.160	402	525	408	587	334	340	95	170	38	720x570x770	48
W8 Top 30 BX	0.35	1ph	8	310	340x360 h.160	402	525	408	587	334	340	95	170	38	720x570x770	48
W8 Top 30 DX 12	0.45	1ph	12	310	340x360 h.160	402	525	408	587	334	340	95	170	38	720x570x770	48
W8 Top 40 DX	0.75	1ph	20	410	430x410 h.170	493	585	422	630	390	430	99	180	56	760x640x770	66
W8 Top 40 BX	0.75	1ph	20	410	430x410 h.170	493	585	422	630	390	430	99	180	56	760x640x770	66
W8 Top 50 DX	0.75	1ph	20	510	545x460 h.190	609	640	420	605	430	540	90	210	70	840x870x750	86
W8 Top 50 BX	0.75	1ph	20	510	545x460 h.190	609	640	420	605	430	540	90	210	70	840x870x750	86
W8 Top 50 DX DB	0.75	1ph	20	410x2	545x460 h.190	609	640	420	605	424	428	90	210	75	840x870x750	87
W8 Top 50 BX DB	0.75	1ph	20	410x2	545x460 h.190	609	640	420	605	424	428	90	210	75	840x870x750	87
W8 Top 70 BX 40 TB P	1.1	3ph+N	40	640x1 / 410x2	780x490 h.190	877	674	1134	1368	424	660	95	200	167	1200x800x1350	180