



TC 12E



TC 22E

TC 12E-22E

tritacarne

meat grinders

- Costruzione in alluminio pressofuso lucidato
- Riduttore tritacarne a bagno d'olio
- Bocca ed elica tritacarne in ghisa trattata per uso alimentare, su richiesta anche in acciaio inox Aisi 304
- Piastra e coltello inox

Versione CE con:

- Comandi IP54 con NVR

Opzioni:

- Comandi con inversione
- TC 12: kit insacatrice, imbuto ø 14-19-23
- TC 22: kit insacatrice, imbuto ø 10-16-25

- Polished die-cast aluminum construction
- oil bath gearbox meat grinder
- Mouth and propeller mincer in untreated cast iron for food, on request in Aisi 304 stainless steel
- S7steel plate and knife

CE version with:

- IP54 protection rated controls and NVR device

Optionals:

- Reverse
- TC 12: stuffer kit, funnels ø 14-19-23
- TC 22: stuffer kit, funnels ø 10-16-25



Optionals



Passapomodoro per TC/TCG 12E

Tomato press for TC / TCG 12E



Passapomodoro per TC/TCG 22E

Tomato press for TC / TCG 22E

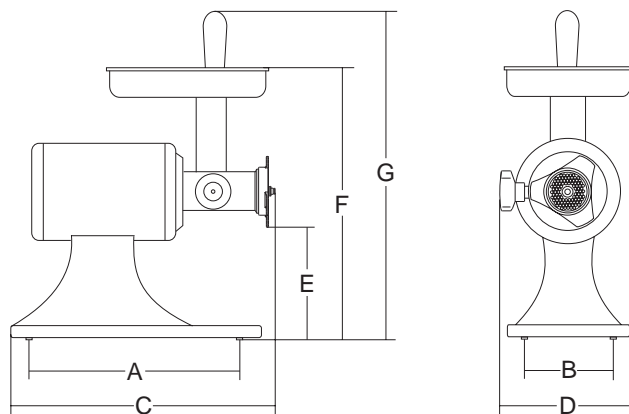

	watt/HP	Kg/10 min.	ø mm	mm	mm	mm	mm	mm	mm	mm	mm	kg	mm	kg
TC 12 E	735/1	1ph/3ph	25	4.5	225	185	430	215	140	445	520	18	320x460x470	20
TC 22 E	800/1.2	1ph/3ph	33	4.5	225	185	440	215	135	445	520	21	320x460x470	23