



TC 12-22 DAKOTA / FX

tritacarne

meat grinders

- Facilmente trasportabile grazie alle pratiche maniglie.
- Corpo in alluminio anodizzato e fianchi in ABS antiurto o in acciaio inox
- Generoso motore ventilato.
- Sistema di riduzione ad ingranaggi a bagno d'olio.
- Ingranaggi elicoidali temperati e rettificati.
- Bocca tritacarne in acciaio inox AISI 304 (o alluminio su mod. 22).
- Piastra e coltello inox.
- Comandi con inversione di marcia di serie.

Versione CE con:

- Comandi 24 volt con NVR.

Opzioni:

- TC 12: kit insacatrice, imbuti \varnothing 14-19-23
- TC 22: kit insacatrice, imbuti \varnothing 10-16-25



TC 22 DAKOTA

- Easily transportable thanks to practical handles.
- Anodized aluminum body and ABS shockproof or s/steel sides.
- Generous ventilated motor.
- reduction system in an oil bath gears.
- hardened and ground helical gears.
- Mouth stainless steel AISI 304 meat grinder (or aluminum on mod. 22).
- S/steel plate and knife.
- Controls with standard reverse gear.

CE version with:

- 24 volt controls and NVR device.

Optionals:

- TC 12: stuffer kit, funnels \varnothing 14-19-23
- TC 22: stuffer kit, funnels \varnothing 10-16-25



TC 22 DAKOTA FX

Optionals



Passapomodoro per TC12

Optional tomato sauce making for TC12

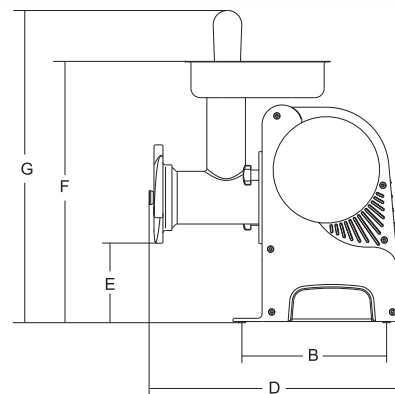
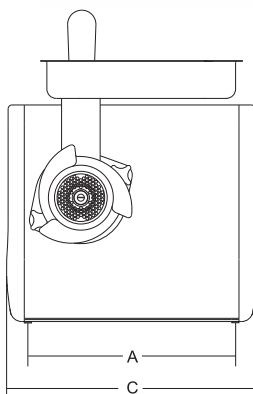

	watt/HP		Kg/h.	\varnothing mm	mm	mm	mm	mm	mm	mm	mm	kg	mm	kg
TC 12 Dakota	1ph 750/1 - 3ph 1.100/1.5	1ph/3ph	95	6	310	225	395	360	130	415	485	24	570x750x800	34
TC 12 Dakota FX	1ph 750/1 - 3ph 1.100/1.5	1ph/3ph	95	6	336	210	450	414	140	405	465	24	570x750x800	34
TC 22 Dakota	1ph 750/1 - 3ph 1.100/1.5	1ph/3ph	120	4.5	310	225	395	360	115	415	485	26	570x750x800	36
TC 22 Dakota FX	1ph 750/1 - 3ph 1.100/1.5	1ph/3ph	120	4.5	336	210	460	450	127	411	472	26	570x750x800	36