



TC 22-32 NEVADA ICE

tritacarne refrigerato

refrigerated meat grinder



YouTube

- Caratteristiche tecniche e performance identiche a mod. non ICE
- Impianto refrigerante 150 Watt con gas R290
- Refrigerazione su collo, bocca e tramoggia
- Comandi inox IP 67 con inversione
- Coperchio plexiglass su tramoggia



YouTube

Opzioni:

- Sistema di protezione interbloccato per uso piastre con foro > 8 mm
- Bocche Unger parziale o totale
- Coperchio inox su tramoggia mod. 32
- Hamburgatrice Format M



YouTube

- *Technical specifications and performance identical to no ICE model*
- *150 Watt, R290 gas refrigerator*
- *Refrigeration on feed tray neck, mincing head and on the whole feed tray*
- *IP 67 protection rated controls with reverse*
- *Plexiglass feed tray lid*

Optionals:

- *Interlock protection for more than 8 mm holes plates (An interlock protection system is required in order to utilize more than 8 mm holes plates)*
- *Partial or total Unger system mincing head*
- *Stainless steel feed tray lid mod. 32*
- *Hamburger press attachment FORMAT M*



133



TC 32 NEVADA ICE



TC 22 NEVADA ICE





Comandi inox IP 67 modelli ICE
S/steel IP 67 protected controls for models ICE



Fissaggio bocca rapido
Fast fixing head system



Comandi inox IP 67
Stainless steel IP 67 protected controls

Optionals

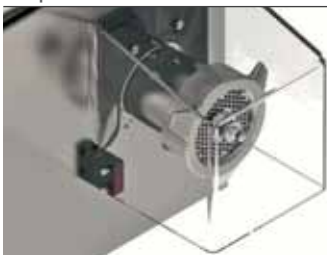

Protezione bocca per piastra con foro $\varnothing > 8$ mm
Safety device for $\varnothing > 8$ mm plates



Standard o enterprise 1/2 Unger Unger Totale



Format M
Format M

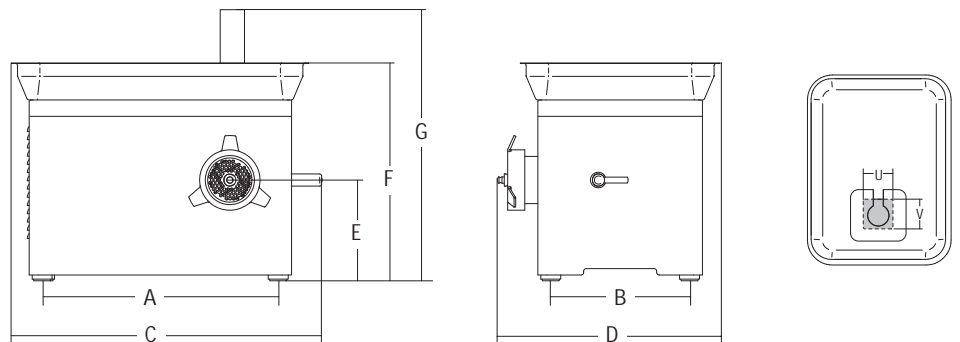

					A	B	C	D	E	F	G	U	V			
	watt/Hp			\varnothing mm	mm	mm	mm	mm	mm	mm	mm	mm	mm	kg	mm	kg
TC 22 Nevada	1ph 1.100/1.5 - 3ph 1.472/2	1ph/3ph	350	4.5	374	221	505	436	111	424	533	64	64	36	750x580x800	39
TC 32 Nevada	1ph 1.840/2.5 - 3ph 2.200/3	1ph/3ph	650	4.5	485	285	633	495	121	450	557	76	76	50	750x580x800	72
TC 22 Nevada Ice	1ph 1.100/1.5 - 3ph 1.472/2	1ph/3ph	350	4.5	374	221	505	435	170	475	585	64	64	48	750x580x800	70
TC 32 Nevada Ice	1ph 1.840/2.5 - 3ph 2.200/3	1ph/3ph	650	4.5	480	285	633	495	121	450	557	76	76	60	750x580x800	82