



TC 22-32 NEBRASKA

tritacarne meat grinder



Industria 4.0



- Tritacarne estremamente compatto che, con il suo sviluppo verticale, permette un notevole risparmio di spazio sul banco di lavoro senza però alcun compromesso su prestazioni ed efficienza
- Disponibile sia con predisposizione hamburgeratrice che protezione piastra con fori maggiori di 8 mm
- Studiata per semplificare qualsiasi eventuale intervento di manutenzione anche direttamente in loco è il modello ideale per macellerie e supermercati con servizio al banco

Opzionali:

- Bocca unger e semiunger
- Hamburgeratrice Format M
- Insacatrice continua
- Protezione per piastre $\varnothing > 8$ mm
- Coperchio plexiglass su tramoggia
- SRCS scheda controllo remoto



TC 22 NEBRASKA

- *Super-compact meat grinder features a tall design that saves space on the worktop without compromising performance or efficiency*
- *Available also with hamburger press attachment and guard for die plates with holes larger than 8 mm*
- *Designed for simple maintenance, even in place, this model is ideal for butchers and supermarket meat counters*

Optionals:

- Half/total unger system
- Patty former Format M
- Stuffer kit
- Safety device for $\varnothing > 8$ mm plates
- Plexiglass feed tray lid
- SRCS wifi control board



TC 32 NEBRASKA

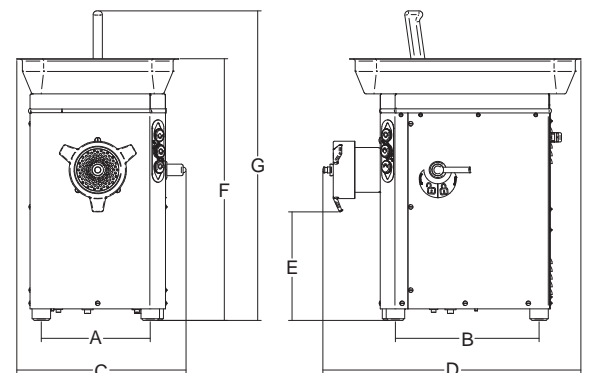

watt/HP

kg/h.

 \varnothing mm

mm

mm

mm

mm

mm

mm

mm

mm

kg

mm

kg

TC 22 Nebraska

1ph 1.100/1.5 - 3ph 1.472/2

1ph/3ph

350

4.5

236

311

350

555

254

566

690

36

760x640x770

44

TC 32 Nebraska

1ph 1.472/2 - 3ph 2.205/3

1ph/3ph

500

4.5

236

310

366

558

235

566

670

43

760x640x770

51