



Industria 4.0



TC 22-32 NEBRASKA ICE

tritacarne refrigerato

refrigerated meat grinder

- Tritacarne refrigerato estremamente compatto che, con il suo sviluppo verticale, permette un notevole risparmio di spazio sul banco di lavoro senza però alcun compromesso su prestazioni ed efficienza
- Impianto refrigerante con gas R290
- Disponibile sia con predisposizione hamburger che protezione piastra con fori maggiori di 8 mm
- Studiato per semplificare qualsiasi eventuale intervento di manutenzione anche direttamente in loco è il modello ideale per macellerie e supermercati con servizio al banco
- Refrigerazione su collo, bocca e tramoggia
- Coperchio plexiglass su tramoggia di serie

Opzionali:

- Bocca unger e semiunger.
- Hamburger Format M
- Insacchiatrice continua
- Protezione per piastra $\varnothing > 8$ mm
- Coperchio tramoggia inox
- SRCS scheda controllo remoto

- *Super-compact refrigerated meat grinder features a tall design that saves space on the worktop without compromising performance or efficiency*
- *R290 gas refrigerator*
- *Available also with hamburger press attachment and guard for die plates with holes larger than 8 mm*
- *Designed for simple maintenance, even in place, this model is ideal for butchers and supermarket meat counters*
- *Refrigeration on feed tray neck, mincing head and on the whole feed tray*
- *Plexiglass feed tray lid, standard*

Optionals:

- *Half/total unger system*
- *Patty former Format M*
- *Stuffer kit*
- *Safety device for $\varnothing > 8$ mm plates*
- *S/steel hopper cover*
- *SRCS wifi control board*



TC 32 NEBRASKA ICE

Coperchio tramoggia in plexiglass di serie
Standard plexiglass feed tray lid

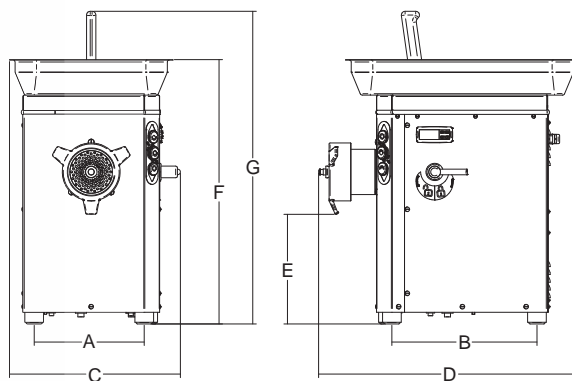

| | Watt/HP | kg/h. | \varnothing mm | mm | mm | mm | mm | mm | mm | mm | mm | kg | mm | kg |
|--------------------|-----------------------------|---------|------------------|-----|-----|-----|-----|-----|-----|-----|-----|----|-------------|----|
| TC 22 Nebraska Ice | 1ph 1.100/1.5 - 3ph 1.472/2 | 1ph/3ph | 350 | 4.5 | 236 | 311 | 350 | 555 | 254 | 566 | 690 | 48 | 760x640x770 | 56 |
| TC 32 Nebraska Ice | 1ph 1.472/2 - 3ph 2.205/3 | 1ph/3ph | 500 | 4.5 | 236 | 310 | 366 | 558 | 235 | 566 | 670 | 60 | 760x640x770 | 68 |