



TC Buffalo



TC Buffalo S



# TC 32 BUFFALO

## tritacarne

### meat grinders

- Grandi prestazioni in una struttura compatta
- La grande disponibilità di accessori la rende adatta sia per l'uso nel banco che nel laboratorio
- Bocca inox esterna con rapido fissaggio a baionetta e paraspruzzi
- Collo introduzione quadro per grande produttività anche in seconda passata
- Sistema di protezione ingranaggi con doppio paraolio
- Motore ventilato per uso continuo
- Comandi inox IP 67 con inversione

#### Opzioni:

- Sistema di protezione contro i sovraccarichi di corrente
- Tramoggia gigante e super (no TC 32 Buffalo S)
- Gambe alte medie e basse (no TC 32 Buffalo S)
- Piano portavassoio estraibile
- Bocca unger e semiunger
- Insacatrice continua
- Sistema di protezione interbloccato per uso piastre con foro > 8 mm
- Predisposizione per Format S con pedaliera

- *Compact heavy duty mincer*
- *Available both table top or floor standing (many optional available)*
- *Stainless steel head with quick bayonette fitting and splash guard*
- *Square feeding neck (high output also with pre-minced meat)*
- *Gear box with double sealing system*
- *Ventilated motor for continuous operation*
- *IP 67 protection rated controls with reverse*

#### Optionals:

- *Overload protection*
- *Larger trays: "gigante" or "super" (not available for TC 32 Buffalo S)*
- *Short, medium, long legs (not available for TC 32 Buffalo S)*
- *Receiving tray holder*
- *Half/total unger system*
- *Stuffer kit*
- *Interlock protection for more than 8 mm holes plates (An interlock protection system is required in order to utilize more than 8 mm holes plates)*
- *Arrangement for Format S with pedal controls*



TC 32 BUFFALO



TC 32 BUFFALO



TC 32 BUFFALO S

## Optionals



Supporto vassoio  
Tray support



Tramoggia gigante  
Larger feed tray



Tramoggia super  
Larger tray super



Gambe con ruote  
Legs with wheels



Protezione bocca per piastra con foro Ø > 8 mm  
Safety device for Ø > 8 mm plates



Standard o enterprise  
1/2 Unger  
Unger Totale



Pedaliera  
Pedal controls

## Standard



Paraspruzzi di serie  
Standard splash guard



Leva avita/svita ghiera di serie  
Standard ring fixing/removing tool

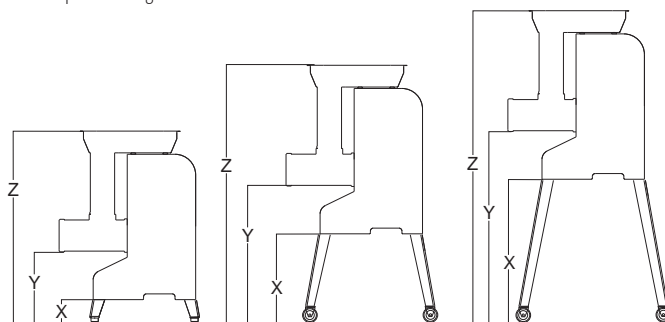

Gambe basse con piedino  
Short legs with feet

X: 131 mm  
Y: 271 mm  
Z: 741 mm

Gambe medie con ruote  
Medium legs with wheels

X: 416 mm  
Y: 556 mm  
Z: 1026 mm

Gambe alte con ruote  
High legs with wheels

X: 688 mm  
Y: 828 mm  
Z: 1298 mm

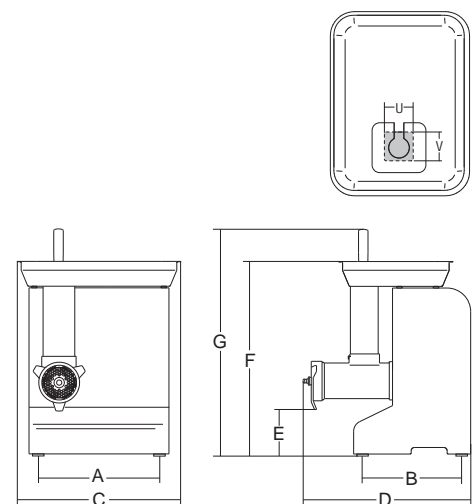

					A	B	C	D	E	F	G	U	V			
	watt/Hp	ph	kg/h.	ø mm	mm	mm	mm	mm	mm	mm	mm	mm	mm	kg	mm	kg
<b>TC 32 Buffalo Hp 3</b>	2.205/3	1ph	700	4.5	385	315	540	540	150	620	720	94	82	65	640x760x850	80
<b>TC 32 Buffalo Hp 4</b>	2.940/4	3ph	700	4.5	385	315	540	540	150	620	720	94	82	65	640x760x850	80
<b>TC 32 Buffalo Hp 4 S</b>	2.940/4	3ph	700	4.5	446	320	625	538	123	592	691	94	82	70	640x760x850	85
<b>Tramoggia standard</b>											535x450x90					
<b>Tramoggia gigante</b>											535x660x90					
<b>Tramoggia super</b>											563x900x120					