



# TC 22-32 BARCELONA

## tritacarne

### meat grinders



YouTube



YouTube



- Tritacarne compatto dalle alte prestazioni
- Comandi IP 54 in 24 Volt con inversione (versione CE)
- Riduttore ermetico a bagno d'olio
- Riduttore protetto dai liquidi da un doppio sistema di isolamento
- Bocca e perno trascinatore in acciaio inox Aisi 304
- Rapido e robusto sistema di fissaggio bocca, blocco rapido bocca brevettato su TC 32
- Versione 22 disponibile anche con collo tondo
- Potenti motori ventilati, per uso continuo
- Motori monofase con protezione termica
- Pratico vano porta piastre e coltelli con coperchio
- Estrema semplicità di pulizia

#### Opzioni:

- Bocca unger e semiunger
- Hamburgatrice Format M
- Insacatrice continua
- Tramoggia gigante
- Coperchio plexiglass su tramoggia
- Gambe medie
- Sistema di protezione interbloccato per uso piastre con foro > 8 mm
- Kit insacatrice imbuti  $\varnothing$  10-16-25

- *Heavy duty compact mincer*
- *IP 54 protection rate, 24 Volt controls, reverse (CE version).*
- *Sealed oil-bath gear box.*
- *Waterproof gear box with double sealing system.*
- *Aisi 304 S/S mouth and feeding worm.*
- *Quick and sturdy head locking system (patented on 32 version).*
- *22 version available also with round feeding neck.*
- *High efficiency ventilated motors for continuous operation.*
- *Thermal protection on single phase motors.*
- *Compartment for knives and plates.*
- *Easy cleaning.*

#### Optionals:

- *Total/half unger system.*
- *Patty former Format M*
- *Stuffer kit.*
- *Oversize tray.*
- *Plexiglass feed tray lid*
- *Medium legs.*
- *Interlock protection for more than 8 mm holes plates (An interlock protection system is required in order to utilize more than 8 mm holes plates).*
- *Stuffer kit, funnels  $\varnothing$  10-16-25*



TC 32 BARCELONA

TC 22 BARCELONA



TC 22 BARCELONA Q

TC 22 BARCELONA T



Vano per piastre e coltelli  
Compartment for knives and plates



Sblocco bocca  
Head locking



Griglie di ventilazione TC ICE  
TC ICE airing take



Comandi TC ICE  
TC ICE controls

## Optionals



Kit insacatrice per TC 22-32  
Stuffer kit for TC 22-32

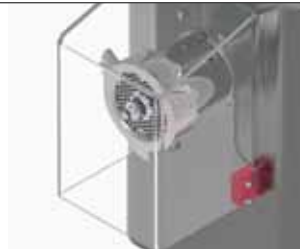

Protezione bocca per piastra con foro Ø> 8 mm  
Safety device for Ø> 8 mm plates



Standard o enterprise  
1/2 Unger Unger Totale



TC 32 BARCELLONA Q ICE H  
con/with Format M

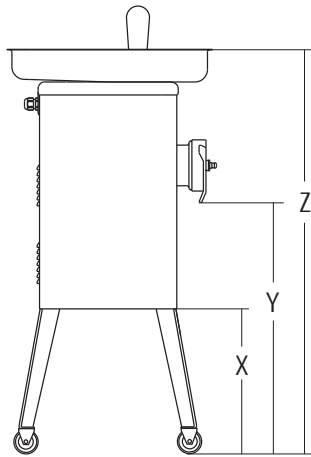

Gambe medie con ruote per TC 32 opzionali  
Optional medium legs with wheels for TC 32  
X: 435 mm  
Y: 685 mm  
Z: 1005 mm

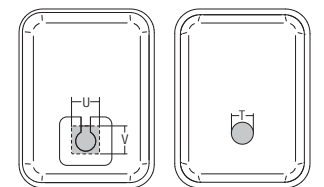
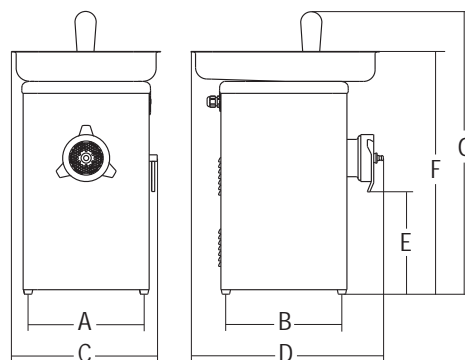

					A	B	C	D	E	F	G	T	U	V			
	watt/Hp		kg/h.	ø mm	mm	mm	mm	mm	mm	mm	mm	mm	mm	mm	kg	mm	kg
<b>TC 22 Barcellona T</b>	1ph 1.100/1.5 - ph 1.472/2	1ph/3ph	300	4.5	252	252	345	484	225	540	622	50	-	-	31	720x570x770	41
<b>TC 22 Barcellona Q</b>	1ph 1.100/1.5 - 3ph 1.472/2	1ph/3ph	350	4.5	252	252	345	484	225	540	645	-	64	64	31	720x570x770	41
<b>TC 32 Barcellona Q</b>	1ph 1.840/2.5 - 3ph 2.200/3	1ph/3ph	500	4.5	244	320	365	560	260	595	700	-	76	76	44	720x570x770	54
<b>TC 22 Barcellona Ice</b>	1ph 1.100/1.5 - 3ph 1.472/2	1ph/3ph	300	4.5	252	252	345	485	225	540	645	-	64	64	30	720x570x770	44
<b>TC 32 Barcellona Ice</b>	1ph 1.840/2.5 - 3ph 2.200/3	1ph/3ph	500	4.5	244	320	365	560	260	595	700	-	76	76	45	720x570x770	58