



TC 22-32 BARCELONA ICE

tritacarne refrigerato

refrigerated meat grinder

- Innovativo e supercompatto tritacarne refrigerato.
- Sistema raffreddante con modulo termoelettrico: senza compressore, senza gas, a risparmio energetico.
- Potenza modulo termoelettrico: 70 Watt
- Raffreddamento su collo e bocca.
- Termometro digitale di controllo.
- Tramoggia e collo inox rimovibili per la pulizia.
- Qualsiasi manutenzione non necessita di frigorista.
- Collo di introduzione quadro per grande produttività anche in seconda passata.
- Motori monofase con protezione termica.
- Blocco rapido bocca brevettato su 32.

Opzioni:

- Bocca unger e semiunger.
- Hamburgatrice.
- Insacatrice continua.
- Tramoggia gigante.
- Coperchio plexiglass su tramoggia
- Gambe medie.
- Sistema di protezione interbloccato per uso piastre con foro > 8 mm. Kit insacatrice imbutoi ø 10-16-25.



TC 32 BARCELONA ICE



TC 22 BARCELONA ICE

- Innovative extremely compact refrigerated mincer.
- Thermo-electric module refrigeration system: without compressor, without gas, energy saving.
- Thermo-electric module power: 70 Watt
- Refrigerated feeding neck and grinding end.
- Self-adjusted temperature.
- Removable and easy to clean S/S tray and feeding neck.
- Easy maintenance (no need of refrigerator technician).
- Square feeding neck (high output also with pre-minced meat).
- Thermal protection on single phase motors.
- Quick and sturdy head locking system (patented on 32 version).

Optionals:

- Half/total unger system.
- Patty former.
- Stuffer kit.
- Oversize tray.
- Plexiglass feed tray lid
- Medium legs.
- Interlock protection for more than 8 mm holes plates (An interlock protection system is required in order to utilize more than 8 mm holes plates). Stuffer kit, funnels ø 10-16-25



Optionals

Gambe con ruote e tramoggia gigante
Legs with wheels and oversize tray



Vano per piastre e coltelli
Compartment for knives and plates



Sblocco bocca
Head locking



Griglie di ventilazione TC ICE
TC ICE airing take



Comandi TC ICE
TC ICE controls

Optionals



Kit insacatrice per TC 22-32
Stuffer kit for TC 22-32

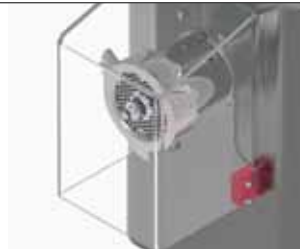

Protezione bocca per piastra con foro Ø> 8 mm
Safety device for Ø> 8 mm plates



Standard o enterprise
1/2 Unger Unger Totale



TC 32 BARCELLONA Q ICE H
con/with Format M

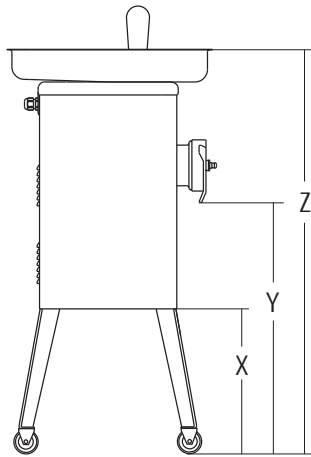

Gambe medie con ruote per TC 32 opzionali
Optional medium legs with wheels for TC 32
X: 435 mm
Y: 685 mm
Z: 1005 mm

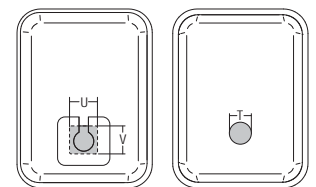
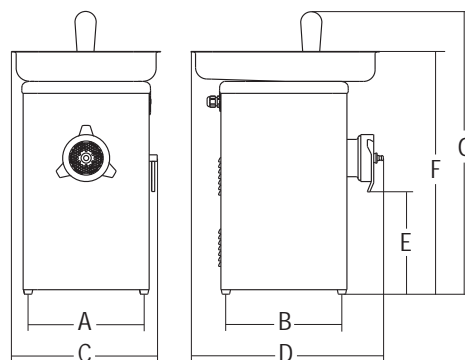

					A	B	C	D	E	F	G	T	U	V			
	watt/Hp				mm	mm	mm	mm	mm	mm	mm	mm	mm	mm	kg	mm	kg
TC 22 Barcellona T	1ph 1.100/1.5 - ph 1.472/2	1ph/3ph	300	4.5	252	252	345	484	225	540	622	50	-	-	31	720x570x770	41
TC 22 Barcellona Q	1ph 1.100/1.5 - 3ph 1.472/2	1ph/3ph	350	4.5	252	252	345	484	225	540	645	-	64	64	31	720x570x770	41
TC 32 Barcellona Q	1ph 1.840/2.5 - 3ph 2.200/3	1ph/3ph	500	4.5	244	320	365	560	260	595	700	-	76	76	44	720x570x770	54
TC 22 Barcellona Ice	1ph 1.100/1.5 - 3ph 1.472/2	1ph/3ph	300	4.5	252	252	345	485	225	540	645	-	64	64	30	720x570x770	44
TC 32 Barcellona Ice	1ph 1.840/2.5 - 3ph 2.200/3	1ph/3ph	500	4.5	244	320	365	560	260	595	700	-	76	76	45	720x570x770	58