



SPIDER 10

impastatrice pizza
pizza dough mixer



Pratica e funzionale impastatrice a spirale con vasca da 10 Lt

Ideale per piccoli impasti sia a livello professionale che amatoriale

- Riduzione con doppio rinvio a cinghia dentata, affidabile e silenziosa
- 5 livelli di velocità variabile
- Timer elettronico
- Termometro per il controllo temperatura impasto
- Luce led in vasca
- Robusta e sicura protezione vasca in acciaio inox interbloccata
- Protezione termica di sovraccarico motore
- Vasca inox con piantone centrale integrato



*Simple and functional spiral mixer with a 10-liter bowl
Ideal for small-scale dough preparations, both for professionals and amateur.*

- *Reliable and quiet dual toothed belt drive*
- *5 variable speed settings*
- *Electronic timer*
- *Thermometer for dough temperature monitoring*
- *LED bowl light*
- *Robust and safe interlocked stainless steel bowl guard*
- *Motor overload thermal protection*
- *Stainless steel bowl with integrated central column*

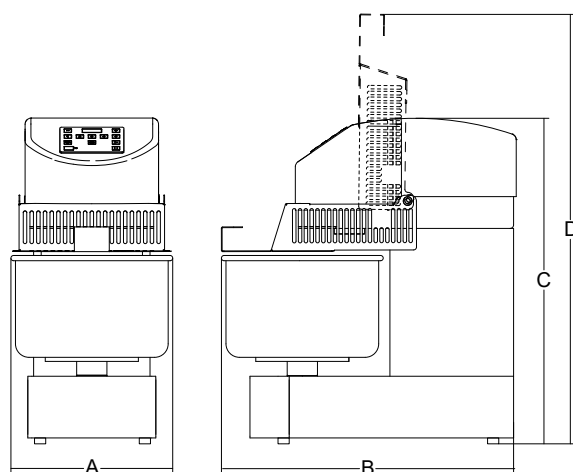

						A	B	C	D	
	watt	ph	lt	kg	mm	mm	mm	mm	mm	kg
Spider 10	700	1ph	10	5	∅ 260x170	278	502	556	737	37