



SHARK

affettatrici gravità gravity slicers

- Fusione in lega di alluminio anodizzato
- Basamento piano per una facile pulizia
- Silenzioso e robusto motore asincrono
- Trasmissione con robusta cinghia poliV
- Lama forgiata a forte spessore
- Scorrimento carrello su boccole autolubrificanti
- Affilatoio incorporato di serie

- Anodized cast aluminum alloy
- Flat base for easy cleaning
- Strong and silent-running asynchronous motor
- Reliable polyV belt drive
- Forged and large thickness blades
- Carriage running on self-lubricating bushes
- Cast-in sharpener is standard



SHARK 300



SHARK 250 - 275

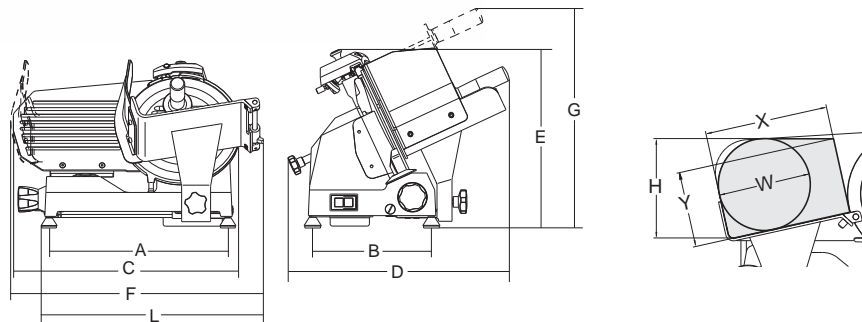

						A	B	C	D	E	F	G	L	X	Y	H	W			
	mm-inch	watt-Hp	mm	mm	mm	mm	mm	mm	mm	mm	mm	mm	mm	mm	mm	mm	mm	kg	mm	kg
Shark 250	250/10"	170/0,23	15	260	230x250	430	275	570	440	415	650	415	550	230	163	190	185	16	630x560x460	19,5
Shark 275	275/11"	170/0,23	15	260	230x250	430	275	590	445	415	650	415	550	225	175	200	195	16,5	630x560x460	20,0
Shark 300	300/12"	240/0,33	15	330	280x300	430	275	590	443	415	650	415	550	215	190	215	210	17,5	630x560x460	21,0