



PLUTONE 7

planetaria
planetary mixer



- Impastatrice planetaria interamente in metallo
- Testa alzabile per smontaggio vasca, sostituzione utensile e pulizia generale
- Vasca smontabile inox da litri 7
- Motore in CC con variatore di velocità
- Trasmissione ad ingranaggi lubrificati a grasso
- Microinteruttori su alzata testa
- Dispositivo NVR
- La macchina è indicata per impasti morbidi, per impasti di media consistenza (es. pane) si consiglia max 1 kg di farina
- NON è adatta per impasti molto duri (es. taralli)

Plutone 7

- Manopola fissaggio rapido testa
- 3 utensili in metallo

Plutone 7 Plus / EL Plus

- Sistema di trasmissione ad ingranaggi ingrandito e potenziato
- Leva fissaggio rapido testa
- 3 utensili in acciaio inox
- Timer da 0 ÷ ∞ per il mod. EL

- *Metal cast planetary mixer*
- *Liftable head for bowl and tools removal and easy cleaning*
- *Removable, S/S, 7L bowl*
- *D.C. motor with speed control*
- *Gear drive and grease lubrication*
- *Safety microswitch on the head*
- *NVR device*
- *Suitable for soft dough, for medium dough (for ex. Bread) it is advisable max 1 kg of flour*
- *NOT suitable for tough mix. (for ex. taralli)*

Plutone 7

- Head fast fixing knob
- 3 metal tools

Plutone 7 Plus / EL Plus

- Upgraded gear system size
- Head fast fixing handle
- 3 s/steel tools
- Timer 0 ÷ ∞ for EL model



PLUTONE 7



PLUTONE 7 EL



Optional



Accessori inox Plutone 7 Plus / EL Plus
Plutone 7 Plus / EL Plus standard s/s accessory

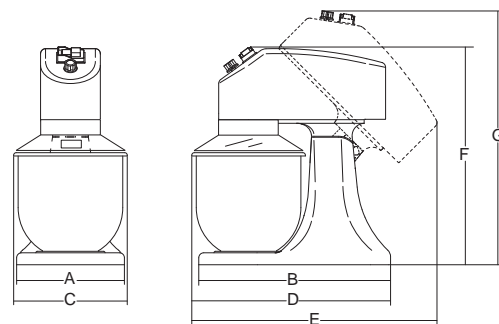

	watt	r.p.m.	lt	mm	mm	mm	mm	mm	mm	mm	mm	kg	mm	kg	
Plutone 7	280	1ph	75 ÷ 660	6,4	ø 220x220	220	285	240	410	450	437	510	14,7	470x320x500	16,9
Plutone 7 Plus	350	1ph	75 ÷ 660	6,4	ø 220x220	220	285	240	410	450	437	510	15	470x320x500	17,4
Plutone 7 EL Plus	350	1ph	75 ÷ 660	6,4	ø 220x220	220	285	240	410	450	437	510	15	470x320x500	17,4