



Industria 4.0

# ORCHESTRA 10

## macchina per la pasta fresca

### *pasta machine*

- Adatta alle esigenze dei piccoli laboratori, grandi ristoranti o mense
- Pratica, veloce ed estremamente facile da pulire e sanificare
- Costruzione in acciaio inox AISI 304
- Struttura autoportante con 4 ruote inox per il modello da pavimento
- Potente motore ventilato con riduzione ad ingranaggi a bagno d'olio
- Performante pala impastatrice facilmente rimovibile
- Coperchio in acciaio inox interbloccato
- Pratica e rimovibile tramoggia per versare la parte liquida in modo ottimale
- Coclea, bocca e ghiera in acciaio inox
- Comandi in acciaio inox IP 67
- Sistema di ventilazione forzata temporizzata anche a motore spento

#### Opzionali:

- Ampia disponibilità di trafilè in bronzo
- Motorino tagliapasta con variatore di velocità
- Motorino tagliapasta automatico con regolazione di velocità e tempo
- Filtro uniformatore
- Raviolatrice e stampi
- Supporto Raviomatic
- RACK: rastrelliera portacassette da cm 60x40 h.7
- DRYER: cassetto asciugapasta
- Kit per raffreddare la bocca in 2 soluzioni:
  - Frio 5: kit con soli tubi per collegamento acqua a perdere
  - Frio R: kit aggiuntivo con pompa di ricircolo
- SRCS scheda controllo remoto

- *Suitable for small workshops and large restaurants or canteens*
- *Reliable, user-friendly and easy to clean*
- *AISI 304 stainless steel body*
- *Self-supporting structure with 4 stainless steel wheels*
- *Powerful, air-cooled motor with oil bath gear box reducer*
- *High-performance and easy to remove kneading paddle*
- *Interlocked stainless steel lid*
- *Convenient removable funnel to add liquid ingredients during processing*
- *Stainless steel worm, head and ring*
- *IP 67 stainless steel controls*
- *Forced air-cooling system for heavy-duty use*

#### Options:

- *Full availability of any kind of dies*
- *Variable-speed pasta cutter*
- *Automatic pasta cutter with adjustable speed and timer*
- *Uniforming filter*
- *Ravioli maker and molds*
- *Raviomatic support*
- *RACK: tray holder from cm 60x40 h.7*
- *DRYER: pasta dryer*
- *Head cooling kit in 2 solutions:*
  - *Frio 5: kit with pipes only for non-returnable water connection*
  - *Frio R: additional kit with recirculation pump*
- *SRCS wifi control board*



ORCHESTRA 10



ORCHESTRA 10 T



## Optionals



Supporto Raviomatic  
Raviomatic support



Frio: Kit per raffreddare la bocca  
Frio: head cooling kit



Tagliapasta  
Pasta cutter



RACK: rastrelliera portacassette cm 60x40 h.7  
DRYER: cassetto asciugapasta  
RACK: tray holder from cm 60x40 h.7  
DRYER: pasta dryer



Tagliapasta automatico  
Automatic pasta cutter



ORCHESTRA 10



ORCHESTRA 10 T

Orchestra 10

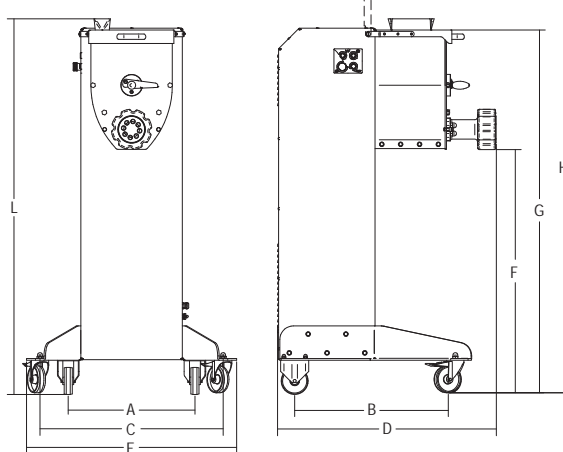

Orchestra 10 T

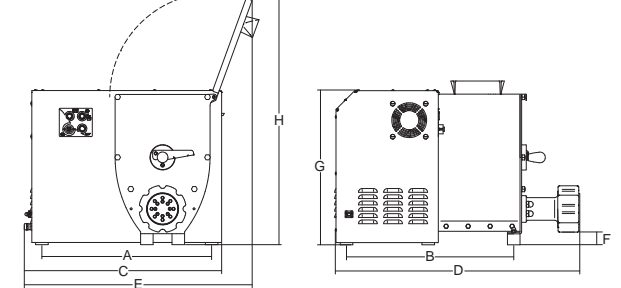

							A	B	C	D	E	F	G	H	L			
	watt/HP	ph	lit	kg	kg/h.	ø mm	mm	mm	mm	mm	mm	mm	mm	mm	mm	kg	mm	kg
<b>Orchestra 10 T</b>	2.250/3	3ph	21	9,8	20	110	540	532	628	778	725	39	493	801	-	72		
<b>Orchestra 10 T 2V</b>	1.875/2,5	1ph	21	9,8	20	110	540	532	628	778	725	39	493	801	-	72		
<b>Orchestra 10</b>	2.250/3	3ph	21	9,8	20	110	470	570	680	812	780	902	1346	1687	1390	118	940x1055x1550	135
<b>Orchestra 10 2V</b>	1.875/2,5	1ph	21	9,8	20	110	470	570	680	812	780	902	1346	1687	1390	118	940x1055x1550	135