



MULTIPATTY

hamburgatrici

hamburger presses



YouTube

- Pratica e robusta formatrice di hamburger con stampi intercambiabili
- Costruzione in alluminio anodizzato e inox
- Stampi autocentranti (sistema Brevettato) per un perfetto accoppiamento di stampo e tampone
- Macchina fornita senza stampi, permette di selezionare a parte gli stampi desiderati
- Sistema automatico sollevamento hamburger per facile rimozione del pezzo
- Opzioni:
- Stampi intercambiabili da Ø mm 100, 130, 150, 180



- *Practical and robust hamburger press with changeable moulds*
- *Made of anodised aluminium and stainless steel*
- *Self-centring moulds (Patented system) for perfect coupling of mould with buffer*
- *Machine supplied without moulds; allows you to select the moulds you require separately*
- *Automatic hamburger lifting system for easy removal of pieces*
- *Optionals:*
- *Changeable moulds in diameter sizes Ø mm 100, 130, 150, 180*





Optionals

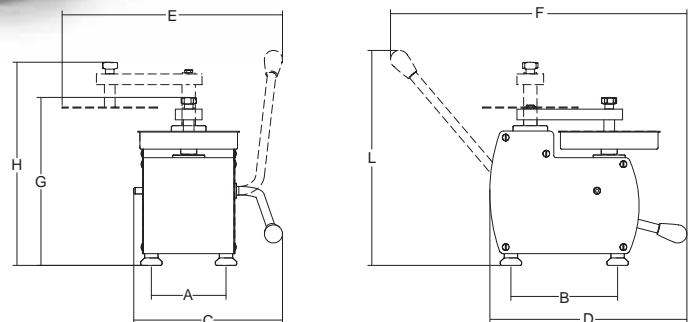

Stampi intercambiabili
Changeable moulds



		A	B	C	D	E	F	G	H	L	
	mm	mm	mm	mm	mm	mm	mm	mm	mm	mm	kg
Multipatty	-	140	200	279	369	-	556	315	381	404	7.5
Stampo / Mould 100	100	-	-	-	-	373	-	-	-	-	1
Stampo / Mould 130	130	-	-	-	-	388	-	-	-	-	1.05
Stampo / Mould 150	150	-	-	-	-	398	-	-	-	-	1.1
Stampo / Mould 180	180	-	-	-	-	413	-	-	-	-	1.2