



YouTube

SRCS



Industria 4.0



LEONARDO EVO

affettatrici verticali

vertical slicers

- Linea arrotondata priva di spigoli e viti a vista
- Affettatrice collocabile su un piano di lavoro da 70 cm
- Lama a costa bassa per minimizzare l'attrito con il prodotto
- Perno di scorrimento, cromato rettificato e lappato
- Ottimo scorrimento del carro grazie alle boccole in ghisa lappate
- Carrello ammortizzato con paracolpi in gomma vulcanizzata
- Parafetta in acciaio inox
- Sistema di tenuta stagna su puleggia
- Puleggia lama senza foro centrale per prevenire infiltrazioni e facilitare la pulizia
- Movimento vela progressivo dei primi 3 mm di apertura, garantisce una maggiore precisione di regolazione taglio delle fette sottili
- Pratico smontaggio del coprilama
- Tutte le minuterie in acciaio inox
- Pulsanti IP 67 in acciaio inox
- Affilatoio con vaschetta inferiore di protezione
- Paragrasso in acciaio inox facilmente smontabile
- Altezza di lavoro agevolata per aiutare l'operatore
- 70 mm di distanza fra lama e corpo macchina
- Estrattore lama di serie

Opzionali:

- Paramano in alluminio per mod. VCS
- Braccio BS3
- SRCS scheda controllo remoto

- *Rounded design and no sharp edges and visible screws*
- *Size can fit 70 cm deep table*
- *Low profile reduced friction blade*
- *Chrome plated ground and lapped slide rod*
- *Smooth sliding thanks to lapped iron bushings*
- *Vulcanised rubber stops on carriage*
- *Stainless steel slice deflector*
- *Enclosed and sealed belt pulley*
- *Blade pulley without centre hole to facilitate cleaning*
- *Adjustable slicer table movement in the first 3 mm of opening, guarantees higher cutting precision*
- *Easily removable blade cover*
- *All stainless steel hardware*
- *Stainless steel pushbuttons with IP67 protection rating*
- *Built in sharpening tool with bottom protection*
- *Easy to remove grease guard*
- *Working height facilitated to help the operator*
- *70 mm distance between blade and motor*
- *Standard Blade Removal Tool (BRT)*

Option:

- *Aluminium hand guard for mod. VCS*
- *BS3 fixing arm*
- *SRCS wifi control board*



LEONARDO 350 EVO BS2 TOP



LEONARDO 385 EVO BS3



LEONARDO 350 EVO BS2



Zavorra smontabile BS2
Removable food pusher BS2



Zavorra smontabile BS3 a tenuta stagna
Removable food pusher BS3 waterproof



Zavorra smontabile VCS
Removable food pusher VCS



Staffa inox anticarto rimovibile
Removable product alignment bar prevents the waste of product



Ampio spazio per la pulizia
Large space for cleaning



Massima vicinanza alla lama
Maximum proximity to the blade



Precisione nel taglio di fette sottili
Higher cutting precision

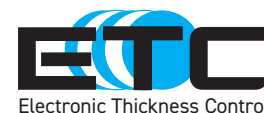

Optionals



Applicazione bilancia:
Pesata max Kg 10 - precisione gr. 2 piatto
smontabile mm 225x360

Scale application:
Weighing 10 kg max - precision gr. 2 removable
platet 225x360 mm

- Apertura vela elettronica con passo da 1/10 di mm
- 8 memorie preimpostabili con nome, modificabili durante l'uso
- Controllo della presenza carrello.
- In caso di rimozione la vela si chiude o non si può aprire.
- WiFi per gestione programmi predefiniti e per manutenzione programmata
- Industria 4.0
- Electronic gauge plate opening with 1/10 mm pitch
- 8 presettable memories with name, adjustable during use
- Carriage presence sensor.
- In case of removal the gauge plate closes and cannot be opened.
- WiFi connection to manage preset programs and for scheduled maintenance



LEONARDO 350 EVO VCS



LEONARDO 385 EVO VCS TOP



LEONARDO 350 EVO BS2 TOP

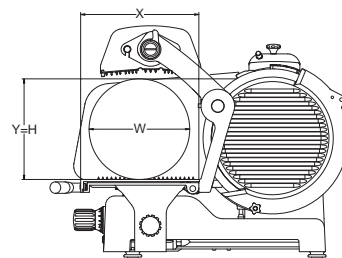
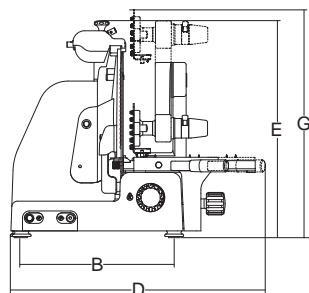
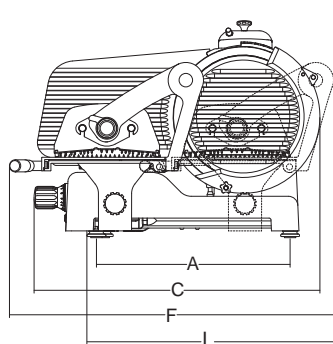

	mm-inch	watt-Hp	mm	mm	mm	mm	mm	mm	mm	mm	mm	mm	mm	mm	mm	mm	mm	kg	mm	kg
Leonardo 350 Evo BS2	350/14"	380/0,52	25	370	350x330	515	410	750	676	567	887	635	677	330	250	250	250	59	870x840x830	75
Leonardo 350 Evo BS3	350/14"	380/0,52	25	370	350x330	515	410	750	676	567	887	650	677	330	253	253	253	59	870x840x830	75
Leonardo 370 Evo BS2	370/15"	380/0,52	25	370	350x330	515	410	760	676	577	887	626	677	330	270	270	270	60	870x840x830	76
Leonardo 370 Evo BS3	370/15"	380/0,52	25	370	350x330	515	410	760	676	577	887	640	677	330	273	273	273	60	870x840x830	76
Leonardo 385 Evo BS2	385/16"	380/0,52	25	370	350x330	515	410	767	676	597	887	626	677	330	280	280	280	61	870x840x830	77

TOP



LEONARDO 350 EVO VCS TOP

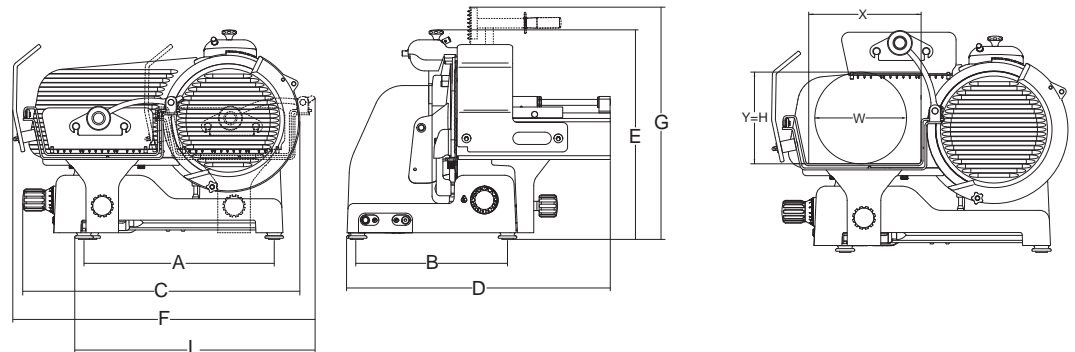

						A	B	C	D	E	F	G	L	X	Y	H	W	kg		
	mm-inch	watt-Hp	mm	mm	mm	mm	mm	mm	mm	mm	mm	mm	mm	mm	mm	mm	mm	kg	mm	kg
Leonardo 350 Evo VCS	350/14"	380/0,52	25	370	430x300	515	410	750	742	570	830	595	656	295	240	240	240	60	870x840x830	76
Leonardo 370 Evo VCS	370/15"	380/0,52	25	370	430x300	515	410	760	742	580	830	586	656	295	258	258	258	61	870x840x830	77
Leonardo 385 Evo VCS	385/16"	380/0,52	25	370	430x300	515	410	770	742	600	830	606	656	295	272	272	272	62	870x840x830	78

TOP