



# HERCULES BIGA 40-50

## impastatrici pizza

### *pizza dough mixers*

- Struttura in acciaio C40 a grosso spessore
- Verniciatura antigraffio a polveri epossidiche alimentare
- Vasca con bordo rinforzato e asta rompi pasta in acciaio AISI 304
- Spirale forgiata
- Coperchio vasca conforme alle normative con foro per aggiunta prodotto in lavorazione
- 2 motori potenti e ventilati con riduttore a vite senza fine a bagno d'olio
- Trasmissioni moto interno con catena rinforzata
- Comandi con display digitale
- 2 velocità di lavorazione più inversione di marcia della vasca

**Opzioni:**

- Ruote
- SRCS scheda controllo remoto

- *Made from large thickness C40 steel*
- *Scratch resistant powder coating*
- *Bowl with reinforced edge and AISI 304 S/S shaft*
- *Forged spiral tool*
- *Lid with opening to add ingredients during operation*
- *Two high efficiency ventilated motors with oil-bath gear box*
- *Reinforced chain drive*
- *Digital display controls*
- *Two speed version and tank reverse*

**Optionals:**

- *Wheels*
- *SRCS wifi control board*



Industria 4.0



Display digitale  
*Digital display*

**Optional**



Ruote  
*Wheels*

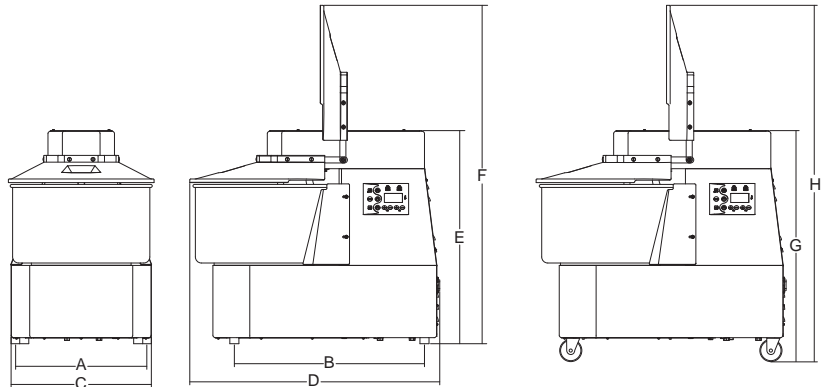

	watt	r.p.m.	r.p.m.	lt	kg	mm	mm	mm	mm	mm	mm	mm	mm	mm	kg	
<b>Hercules Biga 40 2V</b>	750 vasca 1.500/2.200 spirale	3ph	10	82/165	41	32	∅ 452x260	377	630	434	823	705	1115	785	1195	135
<b>Hercules Biga 50 2V</b>	750 vasca 1.500/2.200 spirale	3ph	10	82/165	52	44	∅ 500x270	413	654	470	875	723	1180	809	1266	155

La capacità della vasca e la funzionalità della macchina sono basati su impasti idratati del 60% o superiore  
*The bowl capacity and machine functionality are based on 60% or higher hydrated dough.*