



GALILEO EVO AUTOMATICA

affettatrice gravità gravity slicer

Caratteristiche Galileo Evo Automatica

- Piatto Uniko di serie
- Pulsantiera ergonomica con pulsanti IP67
- 3 regolazioni della velocità
- 3 regolazioni della corsa del carrello
- Conteggio delle fette effettuato
- Impostazione delle fette da tagliare con stop automatico della macchina
- Motore di trasmissione completamente stagno
- Trasmissione del moto con cinghia dentata
- Produzione fette al minuto: 24 - 46

Accessori opzionali:

- Tubo per taglio verdure
- Piatto Nettuno



Features Galileo Evo Automatic

- Standard Uniko hopper
- Ergonomic controls - pushbuttons with IP67 protection rating
- 3 speed selection
- 3 different adjustments run for carriage.
- Slice counter
- Slice number setting with automatic stop feature
- Enclosed and sealed drive motor
- Positive drive belt
- Output slices per minute: 24 - 46

Optional accessories:

- Vegetables cufe
- Nettuno hopper



Optionals



Piatto Nettuno
Nettuno hopper



Tubo per taglio verdure mm ø200 h.345
Vegetables cufe

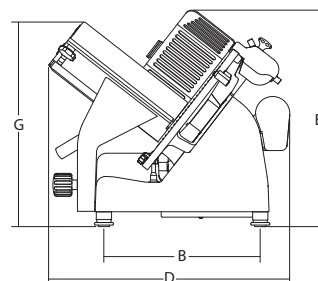
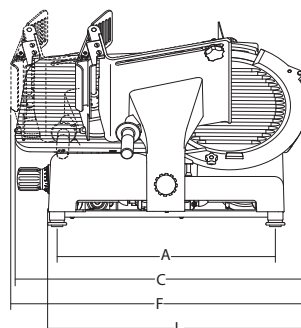
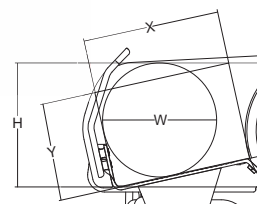

	mm-inch	watt-Hp	mm	mm	mm	mm	mm	mm	mm	mm	mm	mm	mm	mm	mm	mm	mm	kg	mm	kg
Galileo 350 Evo Automatica	350/14"	380+200 0,52/0,27	25	365	350x320	573	410	745	632	558	782	656	677	320	210	275	250	62	870x840x750	78
Galileo 370 Evo Automatica	370/15"	380+200 0,52/0,27	25	365	350x320	573	410	764	632	568	787	667	680	320	230	290	270	63	870x840x750	79
Galileo 385 Evo Automatica	385/16"	380+200 0,52/0,27	25	365	350x320	573	410	768	632	568	791	667	687	320	240	305	280	64	870x840x750	80

